

SHIRE[®]

WORK BOAT AND



JOHN DEERE

MARINE ENGINE RANGE

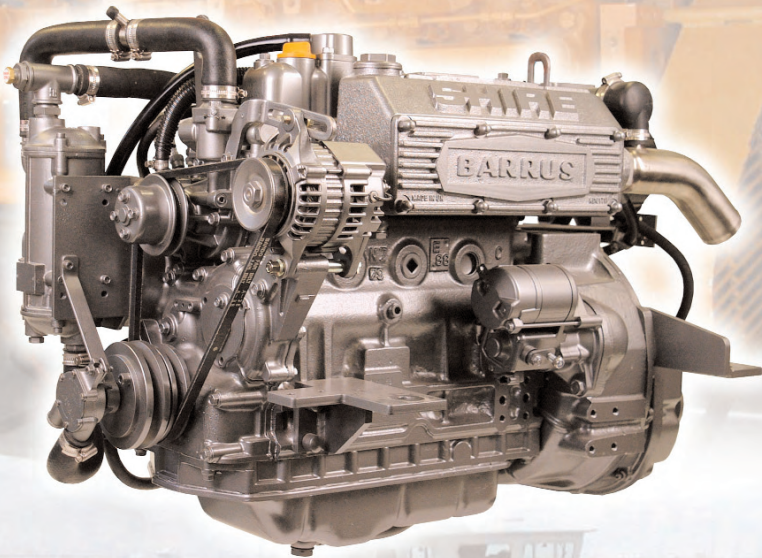

'Quietly leading the way...'

SHIRE 50WB



SPECIFICATIONS

Yanmar	4 stroke, water-cooled diesel
Number of cylinders	4
Bore x stroke	88mm x 90mm (3.30"x 3.54")
Displacement	1204cc
HP (ISO 3046/1)	50hp/3000rpm
Peak torque	108lb ft/1600rpm
Combustion	Direct injection
Electrical system	Starting motor D.C. alternator 12V 50 amp
Cooling system	Heat exchanger
Lubrication system	Forced lubrication by trochoid pump
Reduction and reversing gear	PRM 150 hydraulic
Reduction ratio	2.09:1
Dry weight (engine and gearbox)	181kg

12 Volt electric start	●
Heavy duty feet & flexible engine mounts	●
Electric fuel stop solenoid with mechanical override	●
Morse type cable fittings on speed & gear control	●
Low noise air silencer and cleaner	●
Sump oil extraction pump fitted	●
50 amp alternator 12V	●
Water injection elbow	●
Flexible fuel lines to RCD (ISO 7840)	●
Fuel filter with water separator	●
PRM 150 hydraulic gearbox with 3:1 reduction	▲
Control panel includes tacho, hourmeter, visual & audible alarm, oil temp and volt gauges	▲
Centaflex flexible drive coupling	▲
PRM 260 Hydraulic gearbox	▲
Aquadrive unit	▲

● = STANDARD ▲ = OPTIONAL EXTRA

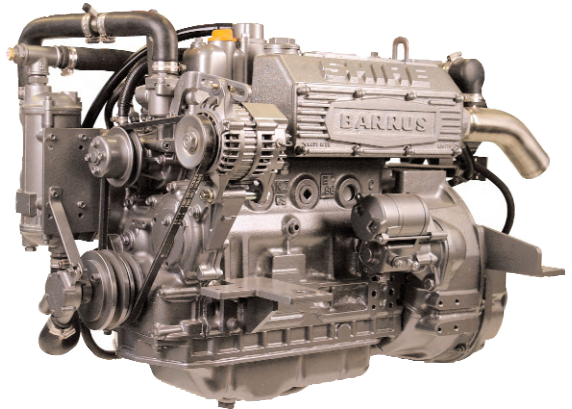

CONTROL PANEL

All measurements in millimetres



TORQUE & FUEL CONSUMPTION

4TNE88

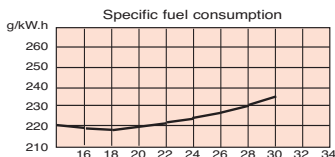
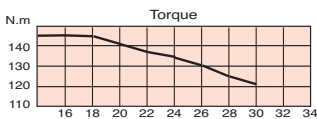

DIMENSIONS

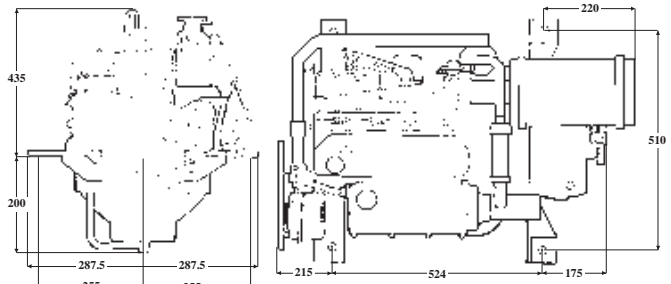

SHIRE[®] 60WB



SPECIFICATIONS

John Deere	4 stroke, water-cooled diesel
Number of cylinders	3
Bore x stroke	106mm x 110mm (4.19"x 5.00")
Displacement	2500cc
HP (3046/1)	60hp/2500rpm
Peak torque	143lb ft/1400rpm
Combustion	Direct injection
Electrical system	Starting motor D.C. 12V - 1.2 kW 12V 80 amp alternator
Cooling system	Keel cooled
Lubrication system	Forced lubrication by trochoid pump
Reduction and reversing gear	PRM 260 hydraulic
Reduction ratio	2:1 or 3:1
Dry weight (engine and gearbox)	384kg

Hurth Gearbox	▲
12 Volt electric start	●
Control panel inc tacho, hour meter, visual & audible alarm, oil, temp & volt gauges	●
Heavy duty feet	●
Flexible engine mounts	●
Electric stop	●
Morse type cable fittings on speed & gear control	●
Low noise air silencer and cleaner	●
Calorifier connections	●
Dry exhaust flange or water injected elbow	●
Sump oil extraction pump fitted	●
80 amp alternator 12V	●
Flexible fuel lines to RCD (ISO 7840)	●
Insulated return electrics 12 or 24V	▲
Centaflex flexible drive coupling	▲
Aquadrive unit	▲

● = STANDARD ▲ = OPTIONAL EXTRA

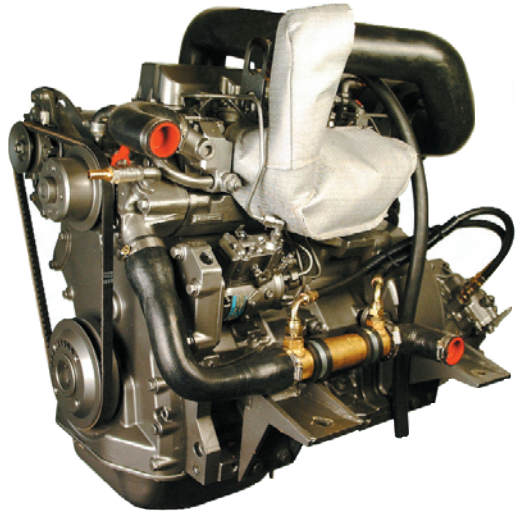

CONTROL PANELS

All measurements in millimetres

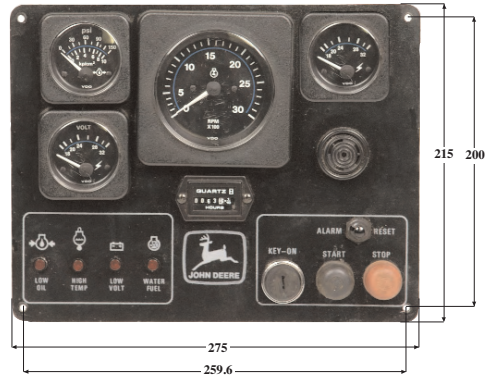

TORQUE & FUEL CONSUMPTION

John Deere 3029

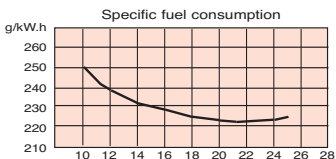
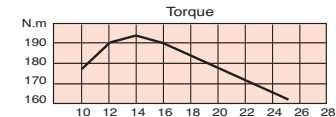

DIMENSIONS

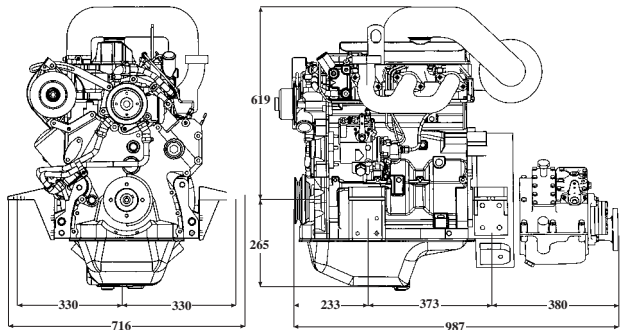



JOHN DEERE

4045DFM



M1 75hp (56kW) M2 85hp (63kW)

SPECIFICATIONS

Model	4045DFM
Number of cylinders	4
Bore and stroke - mm (in)	106 x 127 (4.19 x 5.00)
Displacement - L (cu.in)	4.5 (276)
Aspiration	Natural
Compression Ratio	17.6:1
Length- in. (mm)	37.7 (957)
Width- in. (mm)	28.1 (716)
Height- in. (mm)	36.2 (920)
Weight, dry - lb.(kg)	961 (437)
Max installed angle	
Front up - deg	15
Front down - deg	0

PERFORMANCE DATA

	M2	M1
Rated Gross Power-bhp (kW)	85(63)	75(56)
Rated Speed-rpm	2500	2400
Low Idle Speed-rpm	700	700
Peak torque-lb.ft (N.m)	201(273)	201(273)
Peak Torque Speed-rpm	1400	1400
Fuel Consumption-gal/hr (L/h)		
2500	3.81 (17.3)	N/A
2400	3.30 (15.0)	3.30 (15.0)
2200	2.49 (11.3)	2.49 (11.3)
2000	1.87 (8.5)	1.87 (8.5)
1800	1.39 (6.3)	1.39 (6.3)
1600	1.01 (4.6)	1.01 (4.6)
1400	0.73 (3.3)	0.73 (3.3)
1200	0.48 (2.2)	0.48 (2.2)
1000	0.31 (1.4)	0.31 (1.4)

STANDARD EQUIPMENT

Heat exchanger cooling	Main station instrument panel
12 or 24V starter	30" extension harness
12 or 24V 55A alternator	Wiring loom, senders and switches
Belt guard	Engine running-in oil
Electric stop control	Front and rear engine mounting feet
Morse 33C speed control bracket	Flexible engine mounts
Sump drain pump	Operators manual
Exhaust elbow, 4" water injection	

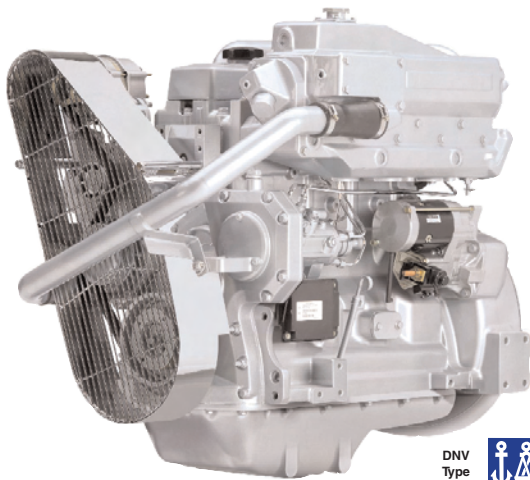

CONTROL PANELS

All measurements in millimetres

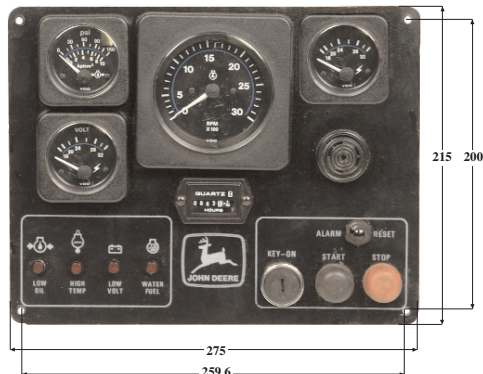

M2 PERFORMANCE CURVE

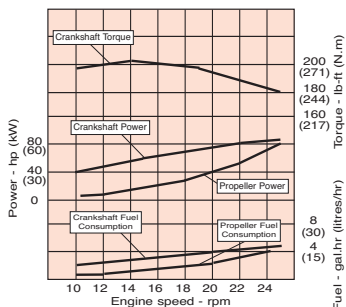

DIMENSIONS

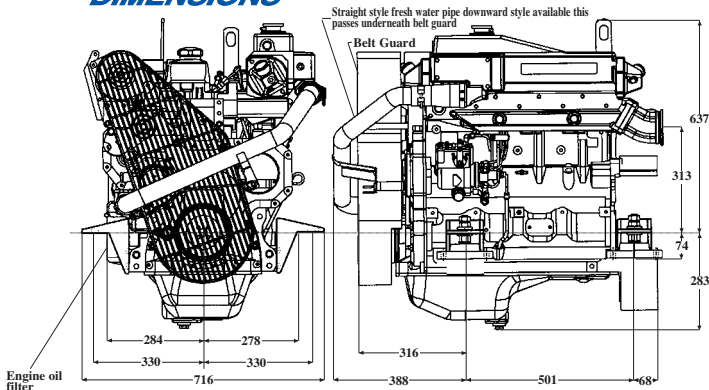

Straight style fresh water pipe downward style available this passes underneath belt guard

Engine oil filter



JOHN DEERE

4045TFM



M1 105hp (78kW) M2 120hp (90kW)
M3 135hp (101kW) M4 150hp (112kW)

SPECIFICATIONS

Model	4045TFM
Type	In-line 4 Cycle
Number of cylinders	4
Bore and stroke - mm (in)	106 x 127 (4.19 x 5.00)
Displacement - L (cu.in)	4.5 (276)
Aspiration	Turbocharged
Compression Ratio	17.2:1
Firing order	1-3-4-2
Combustion system	Direct injection
Total oil capacity, w/filters - Litres	9.0
Length- in. (mm)	40.4 (1026)
Width- in. (mm)	28.1 (716)
Height- in. (mm)	36.5 (928)
Weight, dry - lb.(kg)	1017 (462)
Max installed angle	
Front up - deg	15
Front down - deg	0

PERFORMANCE DATA

	M4	M3	M2	M1
Rated Gross Power-bhp (kW)	150 (112)	135 (101)	120 (90)	105 (78)
Rated Speed-rpm	2600	2500	2400	2300
Low Idle Speed-rpm	700	700	700	700
Peak torque-lb-ft (N.m)	374 (507)	339 (460)	339 (460)	339 (460)
Peak Torque Speed-rpm	1800	1500	1500	1500
Fuel Consumption-gal/hr (L/hr)				
2300	6.53 (29.7)	N/A	N/A	N/A
2400	5.74 (26.1)	5.79 (26.3)	N/A	N/A
2200	5.06 (23.0)	4.99 (22.7)	4.99 (22.7)	N/A
2000	3.85 (17.5)	3.81 (17.3)	3.81 (17.3)	3.81 (17.3)
1800	2.97 (13.5)	2.88 (13.1)	2.88 (13.1)	2.88 (13.1)
1600	2.20 (10.0)	2.11 (9.6)	2.11 (9.6)	2.11 (9.6)
1400	1.58 (7.2)	1.54 (7.0)	1.54 (7.0)	1.54 (7.0)
1200	1.10 (5.0)	1.06 (4.8)	1.06 (4.8)	1.06 (4.8)
1000	0.73 (3.3)	0.70 (3.2)	0.70 (3.2)	0.70 (3.2)

STANDARD EQUIPMENT

Heat exchanger cooling	Main station instrument panel
12 or 24V starter	30" extension harness
12 or 24V alternator	Wiring loom, senders and switches
Belt guard	Engine running-in oil
Electric stop control	Front and rear engine mounting feet
Morse 33C speed control bracket	Flexible engine mounts
Sump drain pump	Operators manual
Exhaust elbow, 4" water injection	

M3 & M4 PERFORMANCE CURVES

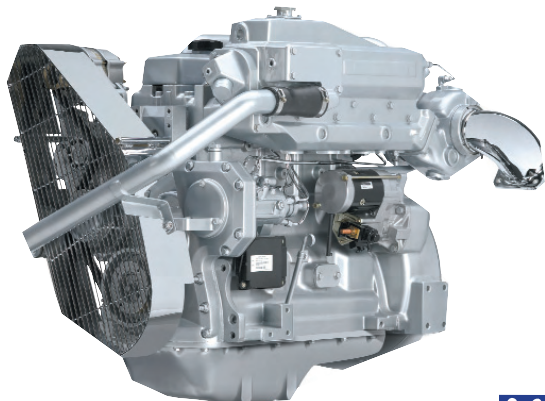
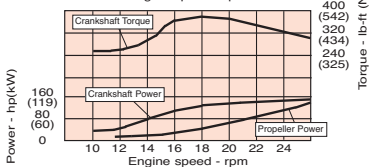
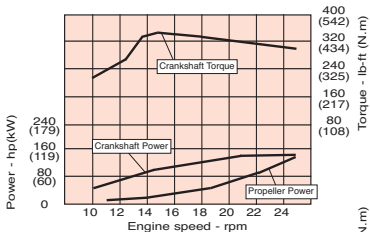

CONTROL PANELS

All measurements in millimeters

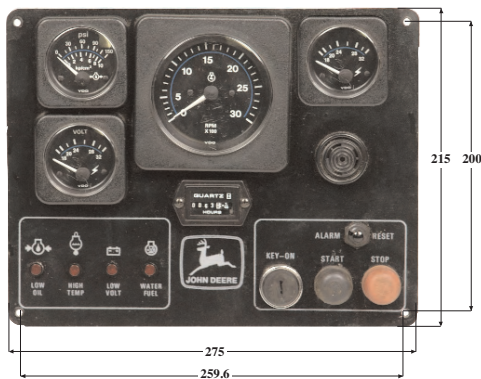

DIMENSIONS

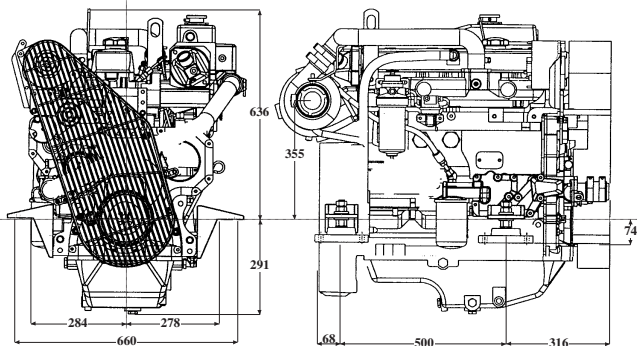



JOHN DEERE

6068TFM



M1 154hp (115kW) M2 175hp (131kW)
M3 200hp (149kW) M4 225hp (168kW)

SPECIFICATIONS

Model	6068TFM	
Type	In-line 4 Cycle	
Number of cylinders	6	
Bore and stroke - mm (in)	106 x 127 (4.19 x 5.00)	
Displacement - L (cu.in)	6.8 (414)	
Aspiration	Turbocharged	
Compression Ratio	17.2:1	
Length- in. (mm)	50.6 (1286)	
Width- in. (mm)	28.1 (716)	
Height- in. (mm)	35 (882)	
Weight, dry - lb.(kg)	1298 (590)	
Max installed angle		
Front up - deg	15	
Front down - deg	0	

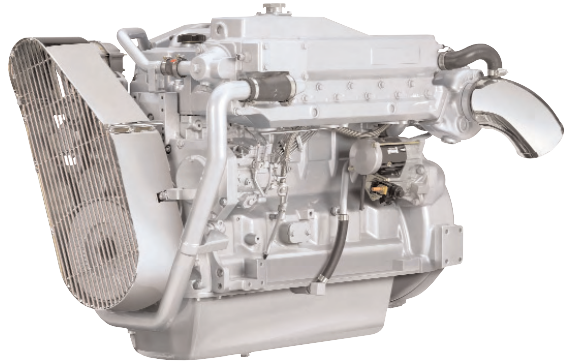

PERFORMANCE DATA

	M4	M3	M2	M1
Rated Gross Power-bhp (kW)	225 (168)	200 (149)	175 (131)	154 (115)
Rated Speed-rpm	2600	2500	2400	2300
Low Idle Speed-rpm	650	650	650	650
Peak torque-lb.ft (N.m)	578 (784)	578 (784)	507 (688)	503 (682)
Peak Torque Speed-rpm	1800	1800	1800	1600
Fuel Consumption-gal/hr (L/h)				
2600	9.75 (44.3)	N/A	N/A	N/A
2500	8.54 (38.8)	8.78 (39.9)	N/A	N/A
2400	7.48 (34.0)	7.57 (34.4)	7.63 (34.7)	N/A
2300	6.53 (29.7)	6.62 (30.1)	6.57 (29.6)	6.62 (30.1)
2200	5.70 (25.9)	5.76 (26.2)	5.67 (25.8)	5.59 (25.4)
2000	4.29 (19.5)	4.36 (19.8)	4.27 (19.4)	4.22 (19.2)
1800	3.17 (14.4)	3.21 (14.6)	3.16 (14.4)	3.12 (14.2)
1600	2.29 (10.4)	2.31 (10.5)	2.29 (10.4)	2.24 (10.2)
1400	1.58 (7.2)	1.61 (7.3)	1.58 (7.2)	1.56 (4.7)
1200	1.06 (4.8)	1.08 (4.9)	1.06 (4.8)	1.03 (4.7)
1000	0.64 (2.9)	0.66 (3.0)	0.64 (2.9)	0.64 (2.9)

STANDARD EQUIPMENT

Heat exchanger cooling	Main station instrument panel
12 or 24V starter	30' extension harness
12 or 24V alternator	Wiring loom, senders and switches
Belt guard	Engine running-in oil
Electric stop control	Front and rear engine mounting feet
Morse 33C speed control bracket	Flexible engine mounts
Sump drain pump	Operators manual
Exhaust elbow, 4" water injection	

M1 & M2 PERFORMANCE CURVES

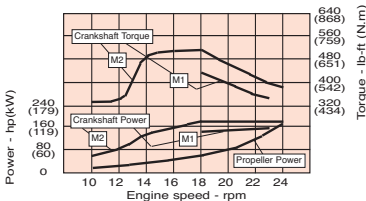

M3 & M4 PERFORMANCE CURVES

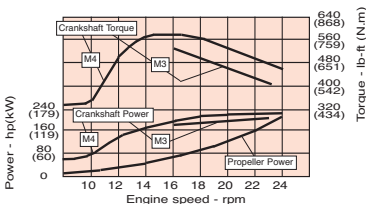

CONTROL PANELS

All measurements in millimeters

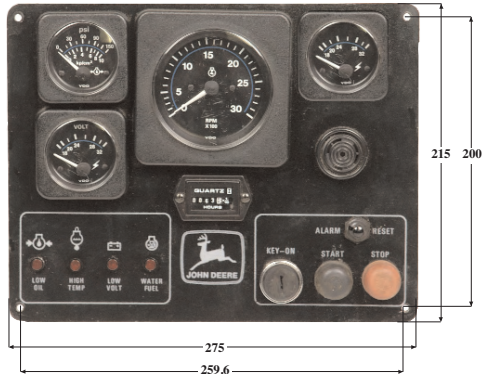

DIMENSIONS

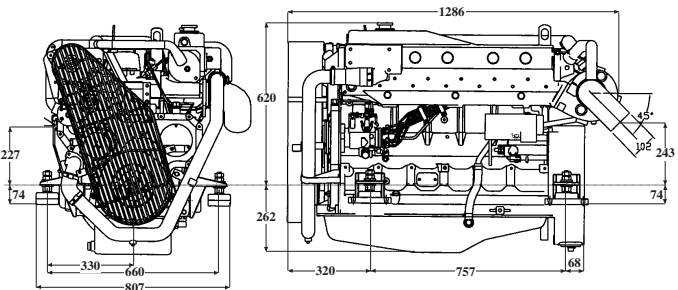



JOHN DEERE

6068SFM



M1 182hp (136kW) M2 208hp (155kW)
M3 236hp (176kW) M4 267hp (199kW) M5 300hp (224kW)

SPECIFICATIONS

Model	6068SFM
Type	In-line 4 Cycle
Number of cylinders	6
Bore and stroke - mm (in)	106 x 127 (4.19 x 5.00)
Displacement - L (cu.in)	6.8 (414)
Aspiration	Turbocharged/Intercooled
Compression Ratio	17.0:1
Length- in. (mm)	52.1 (1325)
Width- in. (mm)	32.6 (829)
Height- in. (mm)	37.3 (947)
Weight, dry - lb.(kg)	1399 (636)
Max installed angle	
Front up - deg	15
Front down - deg	0

PERFORMANCE DATA

	M5	M4	M3	M2	M1
Rated Gross Power-bhp (kW)	300 (224)	267 (199)	236 (176)	208 (155)	182(136)
Rated Speed-rpm	2600	2500	2400	2300	2200
Low Idle Speed-rpm	650	650	650	650	650
Peak torque-lb.ft (N.m)	741 (1005)	719 (975)	674 (915)	629 (853)	612 (830)
Peak Torque Speed-rpm	2000	1800	1600	1600	1500
Fuel Consumption-gal/hr (L/h)					
2600	13.0 (59.1)	N/A	N/A	N/A	N/A
2500	11.0 (50.2)	11.4 (51.6)	N/A	N/A	N/A
2400	9.7 (43.9)	10.0 (45.3)	10.0 (45.5)	N/A	N/A
2300	8.4 (38.2)	8.6 (39.3)	8.8 (40.0)	8.8 (40.1)	N/A
2200	7.2 (32.9)	7.5 (34.1)	7.7 (34.7)	7.7 (34.9)	8.0 (36.4)
2100	6.4 (29.2)	6.6 (29.9)	6.6 (30.2)	6.6 (29.9)	6.9 (31.4)
2000	5.6 (25.3)	5.6 (25.4)	5.7 (26.1)	5.7 (26.2)	5.8 (26.5)
1800	4.2 (18.9)	4.2 (19.1)	4.3 (19.4)	4.1 (18.8)	4.2 (19.2)
1600	2.9 (13.4)	2.9 (13.4)	3.0 (13.6)	3.0 (13.6)	3.0 (13.6)
1400	2.0 (9.3)	2.0 (9.4)	2.0 (9.4)	2.0 (9.4)	2.0 (9.4)
1200	1.3 (6.1)	1.3 (6.1)	1.3 (6.1)	1.3 (6.2)	1.3 (6.1)
1000	0.9 (3.9)	0.9 (3.9)	0.9 (3.9)	0.9 (3.9)	0.9 (4.0)

STANDARD EQUIPMENT

Heat exchanger cooling	Main station instrument panel
12 or 24V starter	30" extension harness
12 or 24V alternator	Wiring loom, senders and switches, ECU
Belt guard	Engine running-in oil
Electric stop control	Front and rear engine mounting feet
Morse 33C speed control bracket	Flexible engine mounts
Sump drain pump	Operators manual
Exhaust elbow, 5" water injection	

M4 PERFORMANCE CURVE

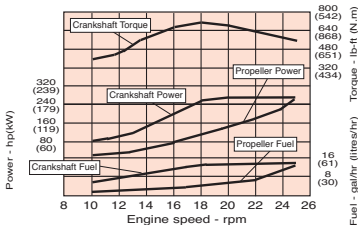

M5 PERFORMANCE CURVE

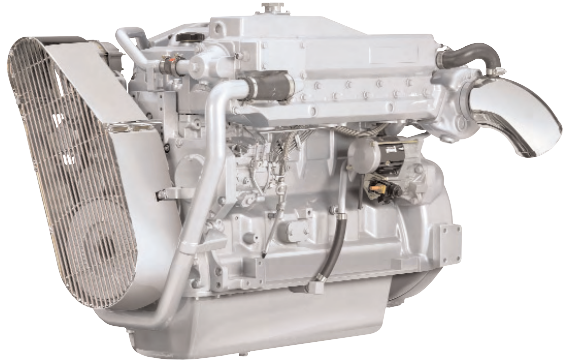
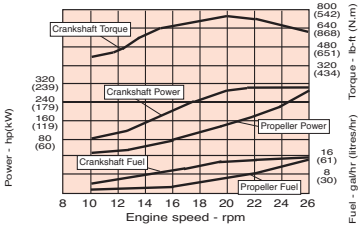

CONTROL PANELS

All measurements in millimetres



DIMENSIONS

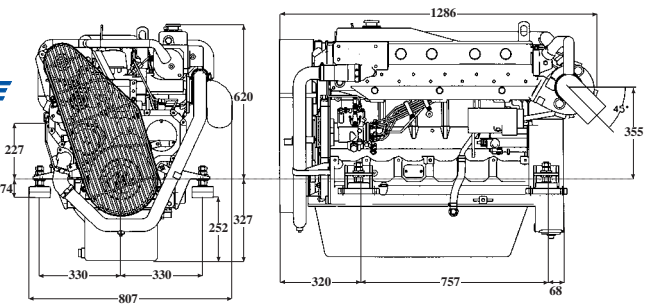

SHIRE. 275WB



M1 134hp (100kW) M2 235hp (175kW)
M3 275hp (205kW)

SPECIFICATIONS

Model	Dong Feng D683
Type	In line 4 Cycle
Number of cylinders	6
Bore x stroke	114mm x 135mm
Displacement- L	8.27
Aspiration	Turbocharged/Intercooled
Charge Air Cooling System	Water-to-Air
Length- mm	1450
Height- mm	1010
Width- mm	823
Weight, dry - lb.(kg)	1813 (824)
Max installed angle	
Front up - deg	20
Front down - deg	10

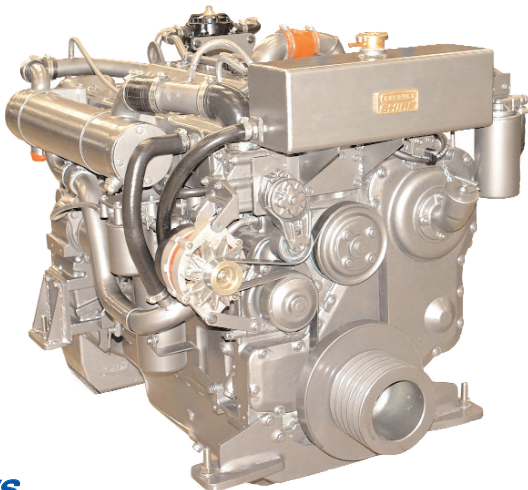

PERFORMANCE DATA

	M3	M2	M1
Rated Gross Power-bhp (kW)	275 (205)	235 (175)	134 (100)
Rated Speed-rpm	2200	1800	1350
Low Idle Speed-rpm	650-700	650-700	650-700

STANDARD EQUIPMENT

- Heat exchanger cooling
- 24V starter
- 24V insulated alternator
- Belt guard
- Electric stop control
- Morse 33C speed control bracket
- Sump drain pump
- Exhaust elbow, 6" water injection
- Main station instrument panel
- 30" extension harness
- Wiring loom, senders and switches
- Engine running-in oil
- Flexible engine mounts
- Operators manual
- Parts list
- 2000hr spares kit
- Gasket set and special tools

DIMENSIONS

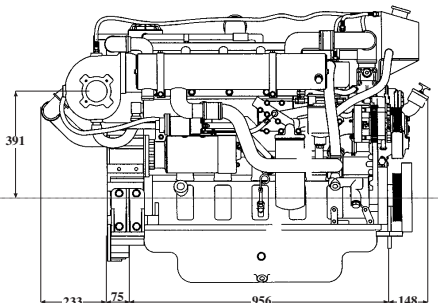
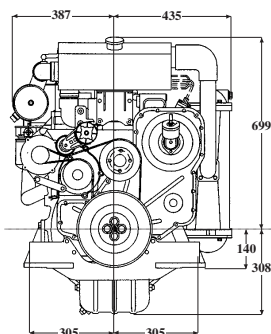

PERFORMANCE AND FUEL CURVES

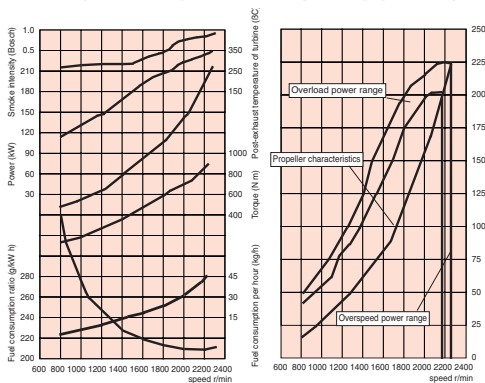

CONTROL PANEL

All measurements in millimetres





JOHN DEERE

6081AFM



M1 235hp (175kW) M2 300hp (224kW)
M3 330hp (246kW) M4 375hp (280kW)

SPECIFICATIONS

Model	6081AFM
Number of cylinders	6
Bore and stroke - mm (in)	116 x 129 (4.56 x 5.06)
Displacement - L (cu.in)	8.1 (496)
Aspiration	Turbocharged
Charge Air Cooling System	Water-to-Air
Engine Type	In-line, 4-Cycle
Compression Ratio	15.7:1
Length- in. (mm)	57.9 (1471)
Width- in. (mm)	34.5 (877)
Height- in. (mm)	40.5 (1030)
Weight, dry - lb.(kg)	1876 (853)
Max installed angle	
Front up - deg	12
Front down - deg	0

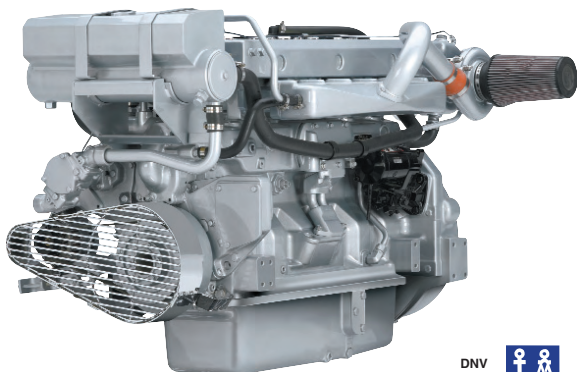

PERFORMANCE DATA

	M4	M3	M2	M1
Rated Gross Power-bhp (kW)	375 (280)	330 (246)	300 (224)	235 (175)
Rated Speed-rpm	2400	2300	2200	2100
Rated Power Fuel Consumption	15.95 (72.5)	13.70 (62.3)	12.45 (56.6)	9.66 (43.9)
Low Idle Speed-rpm	750	700	700	700
Peak torque-lb.ft (N.m)	968 (1312)	899 (1219)	884 (1199)	722 (1046)
Peak Torque Speed-rpm	2000	1900	1700	1600
Propeller Curve				
Fuel Consumption-gal/hr (L/h)				
2400	15.95 (72.5)	N/A	N/A	N/A
2300	13.73 (62.4)	13.70 (62.3)	N/A	N/A
2200	11.99 (54.5)	11.99 (54.5)	12.45 (56.6)	N/A
2100	10.34 (47.0)	10.34 (47.0)	10.76 (48.9)	9.66 (43.9)
2000	8.80 (40.0)	8.80 (40.0)	9.24 (42.0)	8.39 (37.7)
1800	6.36 (28.9)	6.36 (28.9)	6.78 (30.8)	6.00 (27.3)
1600	4.36 (19.8)	4.36 (19.8)	4.58 (20.8)	4.16 (18.9)
1400	3.10 (14.1)	3.10 (14.1)	3.21 (14.6)	3.21 (14.6)
1200	1.94 (8.8)	1.94 (8.8)	2.02 (9.2)	1.83 (8.3)
1000	1.32 (6.0)	1.32 (6.0)	1.32 (6.0)	1.23 (5.6)

CONTROL PANELS

All measurements in millimetres



STANDARD EQUIPMENT

Heat exchanger cooling	Main station instrument panel
12 or 24V starter	30' extension harness
12 or 24V 55A alternator	Wiring loom, senders and switches, ECU
Belt guard	Front and rear engine mounting feet
Electric stop control	Engine running-in oil
Morse 33C speed control bracket	Flexible engine mounts
Sump drain pump	Operators manual
Exhaust elbow, 6" water injection	

M4 PERFORMANCE CURVE

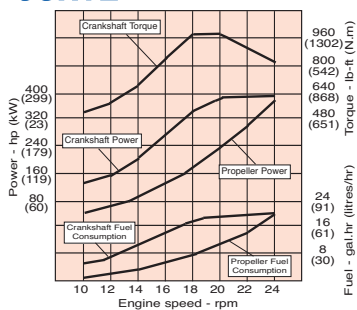

DIMENSIONS

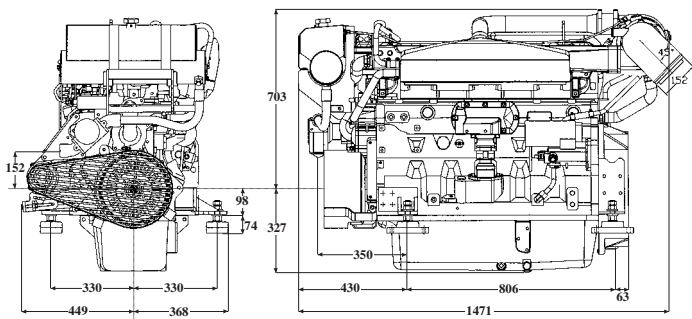



JOHN DEERE

6125AFM



M1 341hp (254kW) M2 389hp (290kW)
M3 455hp (339kW) M4 526hp (392kW)

SPECIFICATIONS

Model	6125AFM
Number of cylinders	6
Bore and stroke - mm (in)	127 x 165 (5.00 x 6.50)
Displacement - L (cu.in)	12.5 (766)
Aspiration	Turbocharged
Charge Air Cooling System	Water-to-Air
Engine Type	In-line, 4-Cycle
Compression Ratio	16.0:1
Length- in. (mm)	53 (1344)
Width- in. (mm)	29 (738)
Height- in. (mm)	48 (1225)
Weight, dry - lb.(kg)	2695 (1225)
Max installed angle	
Front up - deg	12
Front down - deg	0

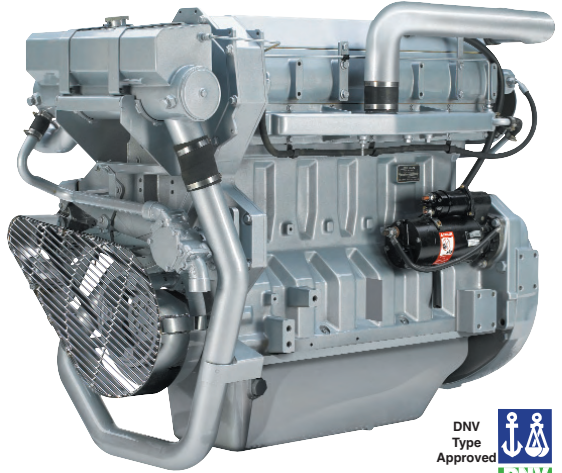

PERFORMANCE DATA

	M4	M3	M2	M1
Rated Gross Power-bhp (kW)	526 (392)	455 (339)	389 (290)	341 (254)
Rated Speed-rpm	2100	2000	1900	1800
Rated Power Fuel Consumption	23.4 (106.5)	20.3 (92.1)	16.6 (75.5)	14.5 (66.2)
Low Idle Speed-rpm	600	600	600	600
Peak torque-lb.ft (N.m)	1624 (2202)	1492 (2023)	1409 (1910)	1409 (1910)
Peak Torque Speed-rpm	1700	1600	1200	1200
Fuel Consumption-gal/hr (L/h)				
2100	23.4 (106.5)	N/A	N/A	N/A
2000	19.5 (88.7)	20.3 (92.1)	N/A	N/A
1900	N/A	N/A	16.6 (75.5)	N/A
1800	14.3 (65.2)	14.3 (65.2)	14.3 (65.1)	14.5 (66.2)
1700	12.0 (54.8)	N/A	N/A	N/A
1600	9.9 (45.3)	9.9 (45.4)	9.9 (45.3)	10.3 (46.6)
1400	6.8 (30.9)	6.8 (30.9)	6.8 (30.8)	7.0 (31.7)
1200	4.3 (19.4)	4.3 (19.4)	4.3 (19.3)	4.4 (19.9)
1000	2.5 (11.5)	2.5 (11.5)	2.5 (11.4)	2.6 (11.8)

CONTROL PANELS

All measurements in millimetres



STANDARD EQUIPMENT

Heat exchanger cooling	Main station instrument panel
12 or 24V starter	30' extension harness
12 or 24V 55A alternator	Wiring loom, senders and switches
Belt guard	Front and rear engine mounting feet
Electric stop control	Engine running-in oil
Morse 33C speed control bracket	Flexible engine mounts
Sump drain pump	Operators manual
Dry exhaust outlet	

M4 PERFORMANCE CURVE DIMENSIONS

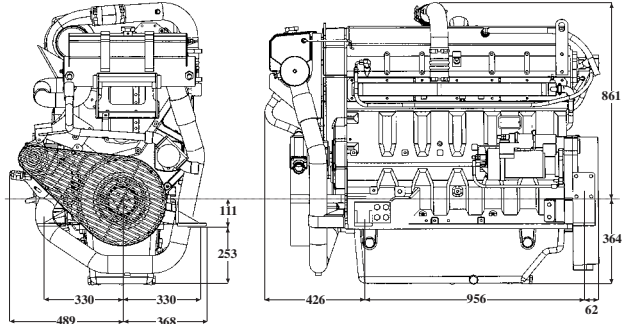
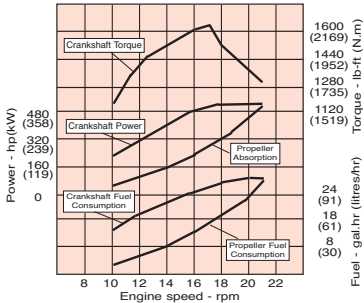

PERFORMANCE RATING **DEFINITIONS**

Marine M1

For propulsion applications that may operate up to 24 hours a day at uninterrupted full power.

Marine M2

For propulsion applications that may utilise full power up to 16 out of each 24 hours of operation.

Marine M3

For propulsion applications that may utilise full power up to 8 out of each 24 hours of operation.

Marine M4

For propulsion applications that may utilise full power up to 2 out of each 24 hours of operation.

Marine M5

For propulsion applications that may utilise full power up to 1 out of each 24 hours of operation.

WARRANTY DIVISION

- 12 months unlimited hours of use.
- 24 months and prior to the accumulation of 2000 hours of use.

For full details of warranty coverage please see the John Deere Off Highway Warranty booklet for John Deere engines and the Shire Warranty Policy for Shire engines.

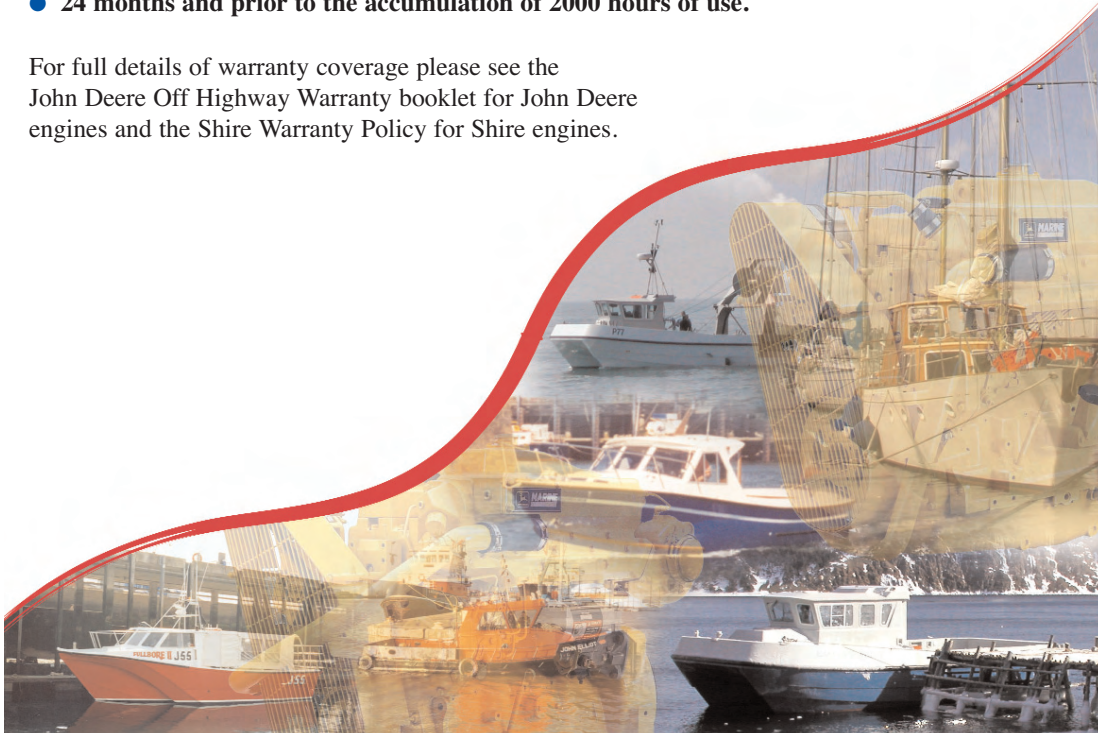

Features & Benefits

- **Extra Alternators**

Barrus are able to supply extra engine mounted alternators of various sizes. For the Shire & John Deere range this includes a 240V option to power microwaves, kettles etc.

- **Sump Drain Pump**

To make it as easy as possible to drain the oil and maintain the engine, we have added a handy sump drain pump.

- **E Coating**

All additional external components are black E coated for extra adhesion and corrosive resistance. E coating is far superior to paint in marine applications and is used by Rolls Royce and other MoD contractors. Other manufacturers avoid using E coating as it is an expensive process.

- **Deckwash Pumps**

We are also able to supply engine mounted electro-magnetic clutch deckwash pumps.

All Shire engines are extensively tested by dynamometers in our state-of-the-art Dyno Shop. The engines are finely tuned, run in and full pre-delivery inspection is carried out before despatch to the customer. Barrus has a wealth of experience in custom building engines for specific end-uses and users, including the RNLI, MoD Navy, MoD Army, MoD Special Forces, H.M. Coastguard and most other professional users. The same exacting standards demanded by these organisations are built into every Shire and John Deere engine.

- **Hydraulic Pumps**

The Shire 275WB is also offered with a hydraulic pump option to run haulers etc.

- **High Torque Levels**

Compare the torque levels with other engines. All models have high torque at low speed.

- **2 Year Warranty**

- **Service & Technical Backup**

Dedicated, first class technical field support.

- **Nationwide Dealer Network**

- **Highest Quality Standards**

All Shire engines are built to the highest quality standards laid down by ISO9001/2000.



Shire production line



5 Dynamometers from 250hp - 1600hp

SPECIALIST DEALER

QUOTATION



E. P. BARRUS LTD. Launton Road, Bicester, Oxon, OX26 4UR.
Tel: 01869 363636 Fax: 01869 363630 tim.hart@barrus.co.uk www.barrus.co.uk

